



SEAMOUNT COLLEGE



THE TRANSITION
 YEAR 
PROGRAMME in



Seamount College, Kinvara

AN OVERVIEW

Parents and Students Information Session



TRANSITION YEAR

Transition Year is a one year school based programme between Junior and Senior Cycle. It is designed to act as a bridge between the two by facilitating the smooth transition from the more dependent learning of the Junior Cycle to the more independent self-directed learning required for the Senior Cycle. TY is a stand alone year.



Transition Year is for:

The Younger students !

Students who are unsure about subject choice or career path -Ty gives a chance to sample a wide variety of subjects, topics, disciplines

Students who need to develop key skills (planning, organisation, confidence, social...)

Students who will put in a valid effort. Participate fully in all activities. Try new things, work experiences.

Students who need to mature

Student who find their strengths outside the standard curriculum



BALANCE IN THE T.Y. CURRICULUM

TRADITIONAL SUBJECTS

NEW MODULES

ACADEMIC SKILLS

SELF-DIRECTED LEARNING

Active Teaching methodologies

Class based learning

Out of school activities

BASIC STUDY HABITS

***THE CAPACITY TO
WORK IN GROUPS***



AIMS of TY

Education for
MATURITY
with emphasis on
social awareness
& increased social
competence

Education through
experience of *ADULT*
& *WORKING LIFE*
as a basis for personal
development &
maturity

Promotion of general,
technical and academic
SKILLS with an
emphasis on
interdisciplinary and
self-directed learning



TY Activities

- * Work experience placements
- * Visiting speakers
- * Outdoor pursuits
- * Excursions
- * Field trips
- * Community care
- * Leadership for Life
- * Future Leaders programme



What is the approach to learning in TY?

- * Project work
- * Teamwork
- * Meeting deadlines
- * Learning by doing-Active Methodologies
- * Learning by teaching
- * Self-directed learning
- * Problem solving
- * Making mistakes and Learning from them!



METHODOLOGIES

- * Active & learner-focused
- * Teacher as facilitator
- * Collaborative learning encouraged
- * Group work / Pair work
- * Role-play /simulations
- * Project work /Fieldwork
- * Out-of-school activities
- * Visiting speakers
- * Negotiated learning
- * Practical work



Developing Confidence/ Maturity

- * Increased social interaction through teamwork.
- * Taking ownership of their work
- * Reflection and evaluation of work experience and other projects
- * Being out of their comfort zone by giving presentations, teaching younger years, roles in the musical.



Structure of our Programme

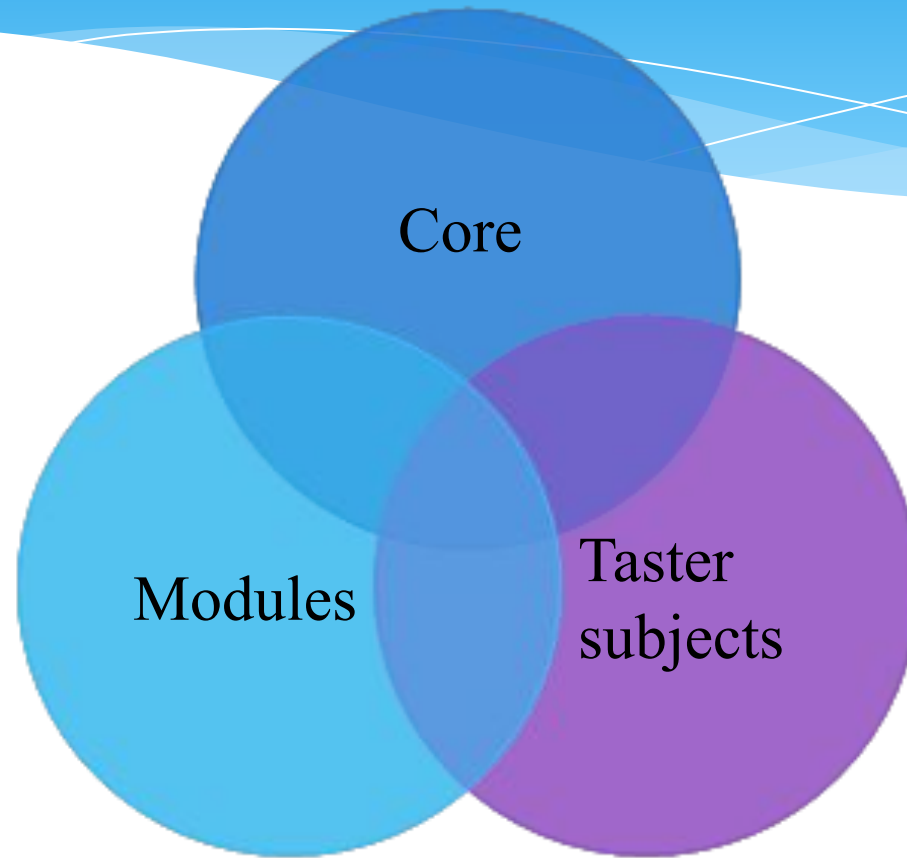

CORE SUBJECT LAYER

- * **Irish**
- * **English**
- * **Maths**
- * **Physical Education**
- * **Social Personal Health Education SPHE**

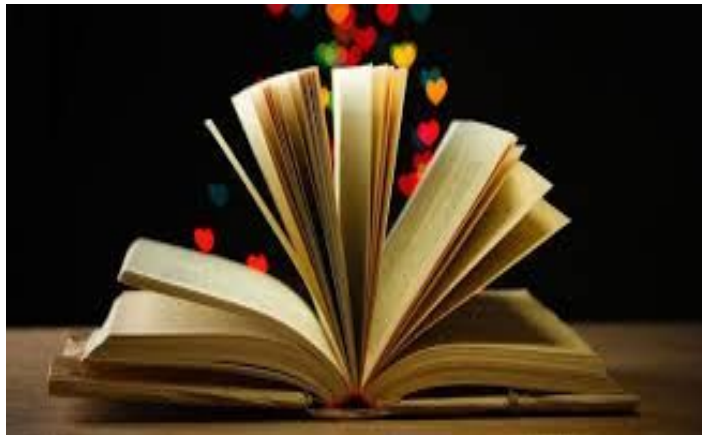



Gaeilge



- 8 week modules
- Culture
- Irish film
- Seachtain na Gaeilge – céilí, tráth na gceist
- Focus on the spoken language.
- Text book
- Logainmneacha projects
- Irish culture (set dancing/ music)
- Áran islands cycling/ language trip



Mathematics



- * 8 week modules - Algebra, Trigonometry, Calculus, Statistics
- * Application of Maths in other subject areas and in the modern world
- * Role of Maths in different careers
- * Online projects
- * Student Presentations in class



English

- * 8 week modules
- * Film appreciation
- * Cinema/ Theatre trip
- * Film studies
- * Debating/ Public Speaking
- * Fiction/ Drama/ Poetry
- * Three Novels



Physical Education

Fitness Profile

Gymnastics

Outdoor Pursuits

Variety of Sports

Future Leaders Programme

Functional Gym Prog

Internal Go-Games



French

- The year is broken down into modules as follows:
 - Hopes & Dreams for TY
 - Me, Myself & I
 - La Francophonie
 - Le cinéma français
 - Overview of LC syllabus (Final term)
- Celebration of European Languages Day
- Journée de la Francophonie .
- Film appreciation - cinema trip

Projects to be completed at end of each module → determine final grade



Religion

- * Follow Liturgical calendar (Christmas, Easter, saints' days etc. Catholic School's week) creating sacred spaces in the school
- * Written projects
- * Meditation
- * Retreat Day
- * Preparation for the TY Graduation
- * Fundraising for Trócaire



SUBJECT SAMPLING LAYER

- * 8 week modular
- * Science -Physics, Chemistry
Biology, Agricultural
Science
- * Music
- * Art
- * Technical Graphics
- * Coding
- * Home Economics
- * Spanish & German



SCIENCE

4 different Science modules:

Physics

Chemistry

Biology

Agricultural Science

Topics covered: DNA and Genetics

Experimental challenges

Energy conservation/ carbon footprint

Topical science

Power Points / written projects

Sci-fest

Opportunity to participate in Young scientists
exhibition

Centres around active learning through investigation
and discovery



Music

- * Musical
- * Music theory
- * Film music
- * Presentation projects
- * Music in advertising/ create an ad
- * Music technology (composing music through Sibelius)
- * Irish traditional dances, ukulele
- * Christmas concert, Carol singing
- * Bodhrán Making workshop
- * Prep for TY graduation

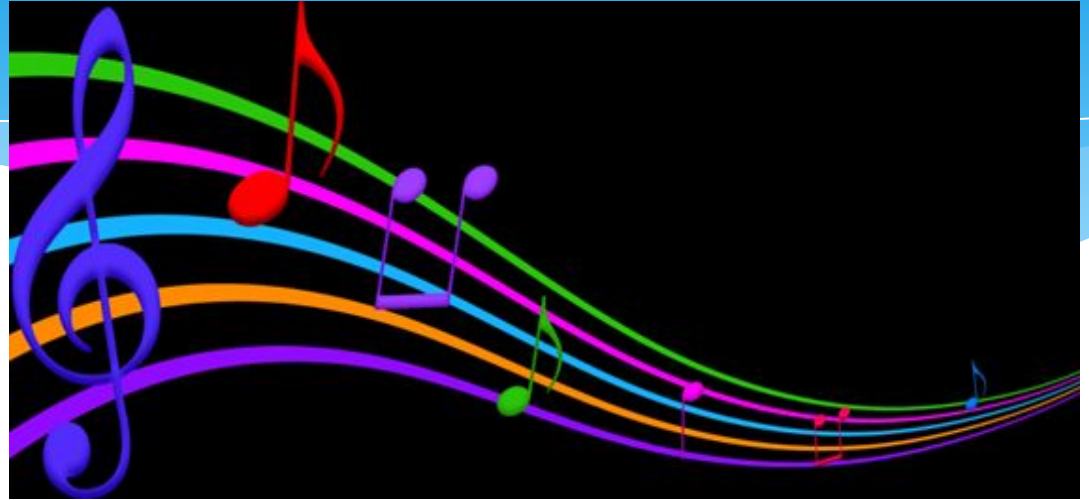

TY module 8 weeks

Portrait painting

Printmaking with lino

Etching

Pottery

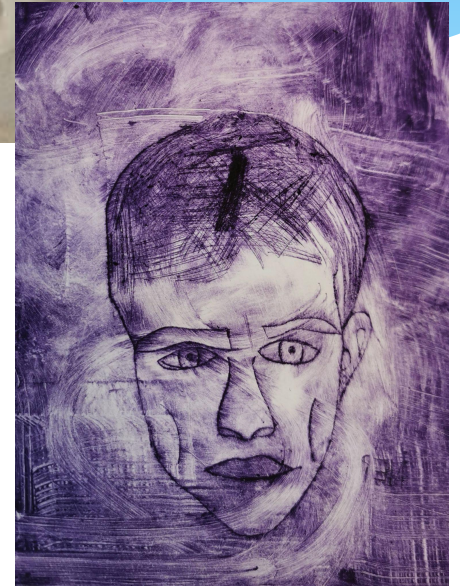

Design & Communication Graphics D.C.G & Technology

- How to produce drawings using drawing equipment & freehand sketches.
- How to read & Interpret drawings & diagrams.
- How graphics relate to design & manufacture of products.
- Produce neat scaled drawings.
- Introduction to Solid Work's (Computer Aided Drawing).

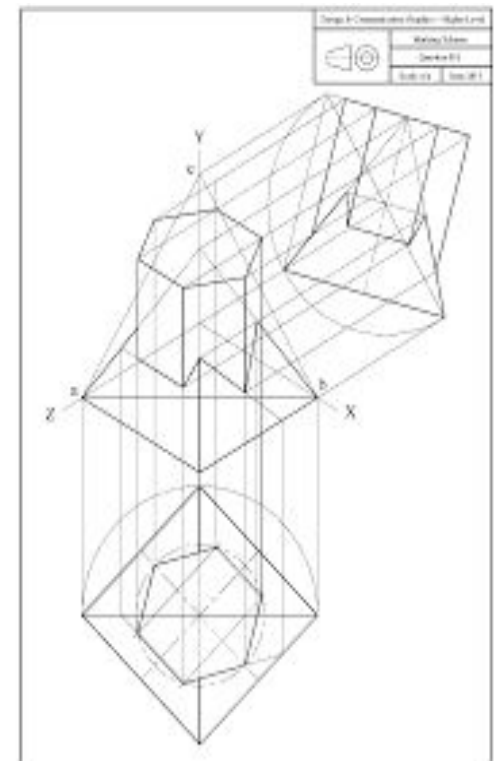

Global Citizenship

- Aims: to increase awareness and understanding of the interdependent and unequal world in which we live, through a process of interactive learning, debate, action and reflection.
- Millennium Development goals
- Charity Fundraising
- Bio Diversity workshop



CODING

Ty students usually take one module of coding.

Coding utilises so many aspects of the Irish school curriculum, art, languages, science and mathematics.

Learning coding helps to transform our young people from digital users into digital creators.

Coding course provides an introduction to the skill needed for so many jobs in the growing IT sector in Ireland and abroad.



Geography

Map work

Regional Geography

Physical

Human

-Geography of Crime & Geography
of Food

Sustainability-Climate Change





Sustainability



Students will get the opportunity to:

- Learn about how to make a positive impact on the environment
- Learn some basic gardening skills such as:
 - Sowing seeds
 - Planting trees
 - Weeding
 - Compost making
 - Making seaweed teas
 - Making leaf mould



Home Economics

- * Home Baking
- * Cooking for College
- * Textiles
- * These modules focus on developing culinary skills and developing confidence in the kitchen

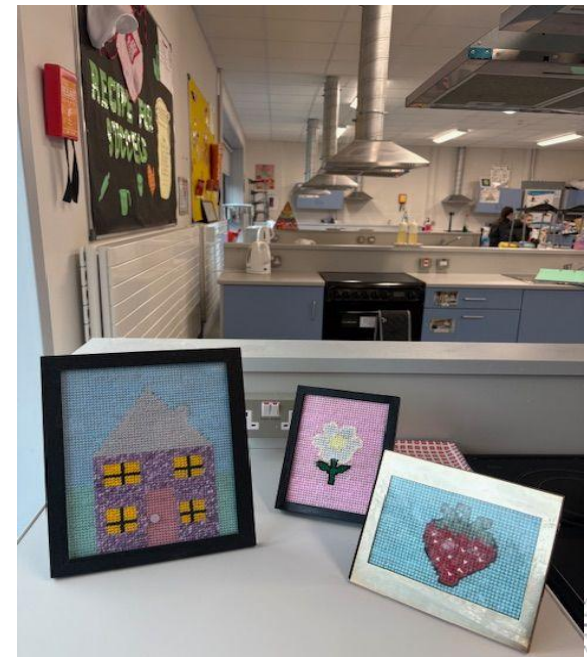

History

Developing the skills of the historian
Civil Right's Movement,
Women in History
Focus on research projects and
presentations in class





TY Photography

- Basics of photography
- Students get a chance to take photos around the school and the village.
- This is a practical and hands-on approach to interacting with the art form.
- Students will also research and study a photographer of their choice
- Some of their work will be displayed in an exhibition at the end of the year as well as being posted on the SCK Photography Club's Instagram account.

Social Responsibility

- * Fundraising for various charities
- * Carol Singing for Nursing Home
- * Work experience with a voluntary organisation
- * Awareness raising - world water day
- * Participation in An Gaisce
- * Global Citizenship Education



Workshops

First Aid Course
Healthy Lifestyle Programme
Bio-diversity workshop
Irish Aid workshop
Bodhrán Making workshop
Galway Simon workshop
Garda Road safety workshop
Internet safety workshop
Film studies workshop



Driver Education



An Garda Road Safety Awareness Workshop

RSA Road Safety Matters



Visitors to the Class

Speakers from various colleges and courses; Business/ Engineering/ Science/ Arts/ Law/ IT



Other programmes/ workshops/ excursions

Team bonding Delphi Overnight trip
Aran Island trip -Inis Oirr
Croke Park tour
An Gaisce President's Awards



GAISCE
THE PRESIDENT'S
AWARD



Assessment

‘Assessment is an integral part of the learning process in Transition Year not separate from it’ (D.E.S.Guidelines)

Varied and continuous assessment

- Written/practical class tests
- Oral/Aural assessment
- Core subjects have written exams at Christmas and summer
- Assessment of attitude, effort, punctuality, attendance, meeting deadlines, participation, student development (confidence, social skills, maturity)
- Assessment of Project work –assessed by individual teachers of specialised subject areas
- Portfolio assessment
- Self assessment
- Peer assessment
- Skills Assessment



Getting back to work and study in 5th year?



wiseGEEK

- TY students are more informed about subject choice for LC and can make decisions based on their strengths.
- Students are more aware of what they hope to pursue career wise and the subjects required.
- Getting back to the regular timetable is easy as students are now more prepared for self directed and independent learning and are studying subjects they are most interested in.



NCCA LONGITUDINAL STUDY

- * Transition Year students are more likely to have goals as they face into Senior Cycle and therefore less likely to repeat the leaving cert.
- * Transition Year provides a solid base for Leaving Cert.



Work Experience



1 day per week (Wednesday)
Students **must source their own** placement relevant to career aspirations

Create a work experience diary
Examples of placements secured: Local businesses, Ballymaloe, Happy Pear, Solicitors of the Future, Law of Ireland, Hospitals, Childcare centres, GPO/ TG4/ Defence Forces/ Galway Clinic/ Marine Institute/ local schools/ vets.....



TY Costs

- * Day Trips/ Modules/ Visits out/ visitors in/ Workshops// Visiting speakers/ Overnight trip to Delphi or any other Adventure Centre.
- * = €550 - €600 approx.
- * The An Gaisce trip / French exchange / a trip abroad may be offered as optional extras. These vary from year to year and are subject to change.



Things to do

- Fill out the application form on the google form and return by Friday, February 27th, 2026.
- Organise work experience for Wednesdays.
- Think about ...Ideas for Sci Fest, BT young Scientist competition, Mini Business etc.
- For more information on TY:
Ty.slss.ie
Ncca.ie
Education.ie

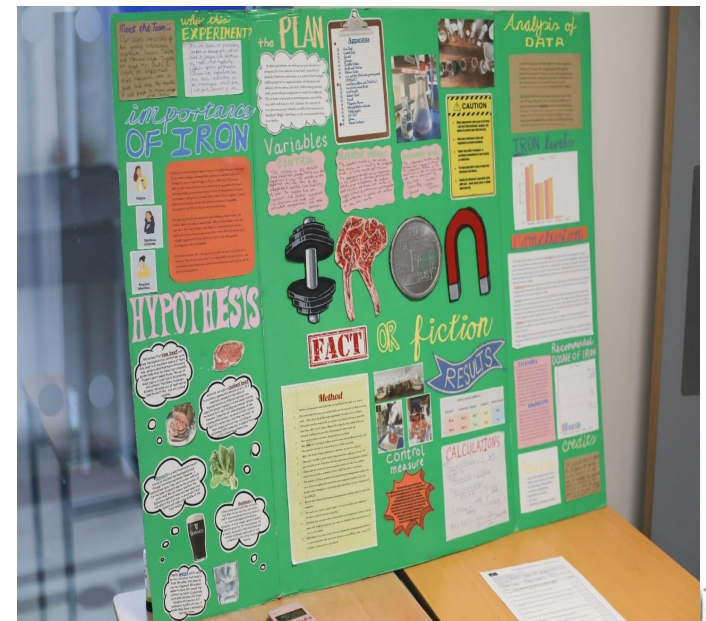

You get out of
Transition Year
what you put in to
the Year
Enjoy!

